



INTERNATIONAL APPLICATION PUBLISHED UNDER THE PATENT COOPERATION TREATY (PCT)

<p>(51) International Patent Classification ⁶ : A61F 11/04, A61D 7/00, A61M 23/00, A61N 1/375</p>	<p>A1</p>	<p>(11) International Publication Number: WO 97/10784 (43) International Publication Date: 27 March 1997 (27.03.97)</p>
<p>(21) International Application Number: PCT/AU95/00622 (22) International Filing Date: 20 September 1995 (20.09.95) (71) Applicant: COCHLEAR LIMITED [AU/AU]; 14 Mars Road, Lane Cove, NSW 2066 (AU). (72) Inventors: PARKER, John; 67A Coolaroo Road, Lane Cove, NSW 2066 (AU). TREABA, Claudiu; 4/39 Belmont Avenue, Wollstonecraft, NSW 2065 (AU). (74) Agent: WATERMARK; Level 4, Amory Gardens, 2 Cavill Avenue, Ashfield, NSW 2131 (AU).</p>	<p>(81) Designated States: AU, CA, JP, European patent (AT, BE, CH, DE, DK, ES, FR, GB, GR, IE, IT, LU, MC, NL, PT, SE). Published <i>With international search report.</i></p>	

(54) Title: BIORESORBABLE POLYMER USE IN COCHLEAR AND OTHER IMPLANTS

(57) Abstract

An implant such as a cochlear assembly, or other similar device, includes an elongated therapeutic member (12) arranged and constructed to perform a therapeutic function. The therapeutic member has at least two configurations: an insertion and a deployed configuration. The first configuration is selected to ease the insertion of the member (12) into a body cavity. A stiffening member (18) is used to urge said therapeutic member (12) toward said first configuration. The stiffening member (18) is made of a bioresorbable material so that after insertion, the stiffening member (18) dissolves and allows the therapeutic member (12) to assume the second configuration.

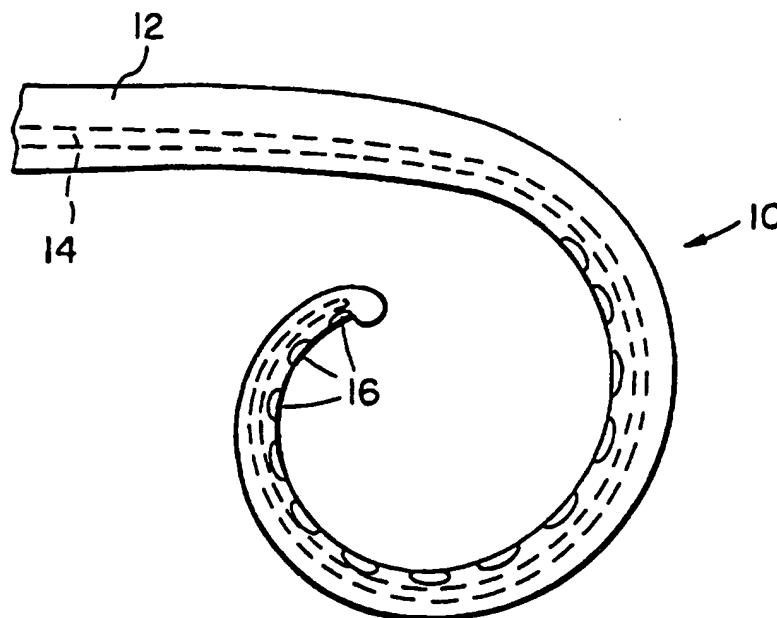

FOR THE PURPOSES OF INFORMATION ONLY

Codes used to identify States party to the PCT on the front pages of pamphlets publishing international applications under the PCT.

AM	Armenia	GB	United Kingdom	MW	Malawi
AT	Austria	GE	Georgia	MX	Mexico
AU	Australia	GN	Guinea	NE	Niger
BB	Barbados	GR	Greece	NL	Netherlands
BE	Belgium	HU	Hungary	NO	Norway
BF	Burkina Faso	IE	Ireland	NZ	New Zealand
BG	Bulgaria	IT	Italy	PL	Poland
BJ	Benin	JP	Japan	PT	Portugal
BR	Brazil	KE	Kenya	RO	Romania
BY	Belarus	KG	Kyrgystan	RU	Russian Federation
CA	Canada	KP	Democratic People's Republic of Korea	SD	Sudan
CF	Central African Republic	KR	Republic of Korea	SE	Sweden
CG	Congo	KZ	Kazakhstan	SG	Singapore
CH	Switzerland	LI	Liechtenstein	SI	Slovenia
CI	Côte d'Ivoire	LK	Sri Lanka	SK	Slovakia
CM	Cameroon	LR	Liberia	SN	Senegal
CN	China	LT	Lithuania	SZ	Swaziland
CS	Czechoslovakia	LU	Luxembourg	TD	Chad
CZ	Czech Republic	LV	Latvia	TG	Togo
DE	Germany	MC	Monaco	TJ	Tajikistan
DK	Denmark	MD	Republic of Moldova	TT	Trinidad and Tobago
EE	Estonia	MG	Madagascar	UA	Ukraine
ES	Spain	ML	Mali	UG	Uganda
FI	Finland	MN	Mongolia	US	United States of America
FR	France	MR	Mauritania	UZ	Uzbekistan
GA	Gabon			VN	Viet Nam

Bioresorbable polymer use in cochlear and other implants

Field of Invention

This invention pertains to implantable devices such as cochlear
5 electrodes incorporating bioresorbable or softening materials, and more particularly to a device which has a first preselected shape suitable for insertion into the body of a patient, and a second shape suitable for providing a specific function, or stimulus, the bioresorbable or softening materials being used to change the device from the second to the first shape.

10 Background of the Invention

The invention is described for electrodes used in cochlear implant systems, however, it is equally applicable to other implantable devices. Cochlear implant systems are used to aid patients having a hearing deficiency. More particularly, these systems include a microphone receiving ambient
15 sounds and converting the sounds into corresponding electrical signals, signal processing means of processing the electrical signals and generating cochlea stimulating signals and an electrode assembly for applying the cochlea stimulating signals to the cochlea of the patient. It is known in the art that the cochlea is tonotopically mapped. In other words, the cochlea can be partitioned
20 into regions, with each region being responsive to signals in a particular frequency range. This property of the cochlea is exploited by providing the electrode assembly with an array of electrodes, each electrode being arranged and constructed to deliver a cochlea stimulating signal within a pre-selected frequency range to the appropriate cochlea region. The electrical currents and
25 electric fields from each electrode stimulate the cilia disposed on the modiola of the cochlea. Several electrodes may be active simultaneously. It has been found that in order for these electrodes to be effective, the magnitude of the currents flowing from these electrodes and the intensity of the corresponding electric fields, are a function of the distance between the electrodes and the
30 modiola. If this distance is great, the threshold current magnitude must be larger

than if the distance is smaller. Moreover, the current from each electrode may flow in all directions, and the electrical fields corresponding to adjacent electrodes may overlap thereby causing cross-electrode interference. In order to reduce the threshold stimulation amplitude and to eliminate cross-electrode interference, it is advisable to keep the distance between the electrode array and the modiola as small as possible. This is best accomplished by providing the electrode array in the shape which generally follows the shape of the modiola. Of course during insertion, the electrode assembly should be generally straight, because otherwise the insertion procedure is too cumbersome and difficult. Several methods and means of curving the electrode assembly have been reported, however in the opinion of the inventors, none of these prior methods are satisfactory. For example, one electrode assembly is known which includes an electrode carrier provided with a longitudinal element arranged on one side of the carrier and constructed to change its dimension once the assembly is inserted. For example, the longitudinal element could include a hydrogel such as PAA (Polyacrylic acid) which expands after insertion by absorbing water from the cochlear fluid. Alternatively, the longitudinal element could be a bimetallic filament (such as nickel/titanium) which is shaped to allow the electrode carrier to take a straight configuration at room temperature but bends into a preselected shape once it is exposed to body temperature. Another proposed electrode assembly included a mechanical member arranged to bend the electrode carrier after the carrier has been inserted. All these prior art devices require a structure which is difficult and expensive to manufacture and which in most cases are not expected to perform satisfactorily.

25 OBJECTIVES AND SUMMARY OF THE INVENTION

In view of the above mentioned disadvantages of the prior art, it is an objective of the present invention to provide a cochlear electrode assembly which has a first, relatively straight configuration so that it can be readily implanted, and a second, curved configuration to conform to the cochlea of a patient, using a material which softens or disassociates in body fluids. A further objective is to provide an assembly which has relatively few parts so that its

cross-section is not too large for implantation. Another objective is to provide an assembly which can be manufactured relatively easily and inexpensively. Other objectives and advantages of the invention shall become apparent from the following description. Briefly, an electrode assembly constructed in accordance
5 with a preferred implementation of this invention includes an electrode carrier constructed and arranged to support a plurality of electrodes suitable for defining an electrode array for application for cochlear stimulation signals. The carrier is preferably preshaped into a curved configuration selected to insure that the electrodes are disposed in close proximity to the modiola of the scala
10 tympani. Prior to implanting, the carrier is embedded in a relatively straight sheath or alternatively a stiffening element or elements are applied to maintain the carrier in a linear configuration. The sheath or the stiffening element or elements are preferably made of a bioresorbable material, such as a polymer which dissolves in the cochlear fluid after implantation. Alternatively, the
15 stiffening element or elements are formed from a material which otherwise disassociates after implantation, or which softens to the extent that the curved configuration is assumed, without the material necessarily disassociating. Preferably the carrier is provided with biasing fins which in the linear configuration are folded against the carrier. Once the sheath is dissolved, the
20 biasing fins flex outwardly away from the carrier to engage the walls of the scala tympani to urge the carrier toward the modiola. Alternatively, the carrier is preformed so that after the sheath dissolves, the carrier assumes the curved shape.

BRIEF DESCRIPTION OF THE DRAWINGS

25 Figure 1 shows a side view of an electrode carrier constructed in accordance with this invention;

Figure 2 shows an electrode assembly constructed in accordance with this invention with the carrier of Figure 1 embedded in a stiffening sheath;

Figure 3 shows a cross-sectional view of the assembly of Figure 2 taken
30 along line 3-3;

Figure 4 shows a cross sectional view of the scala tympani of a patient with the electrode carrier of Figure 1 after the sheath has been dissolved;

Figure 5 shows a longitudinal cross sectional view of an electrode carrier in accordance with a first alternate embodiment;

5 Figure 6 shows a side view of an electrode carrier in accordance with a second alternate embodiment of the invention;

Figure 7 shows the carrier of Figure 6 embedded in a stiffening sheath;

Figure 8 shows a cross sectional view of the assembly of Figure 7 taken along line 8-8;

10 Figure 9 shows the carrier of Figure 7 deployed in the scala tympani, after dissolution of the stiffening sheath;

Figure 10 shows a cross-sectional view of the carrier of Figure 9 taken along line 10-10;

Figure 11 shows a somewhat diagrammatic view of the assembly of Figure 7 being inserted in to the scala tympani;

15 Figure 12 shows a somewhat diagrammatic view of the carrier of Figure 11 deployed in the scala tympani; and

Figure 13 shows the electrode carrier of Figure 11 being withdrawn from the scala tympani.

20 Detailed Description of the Invention

Referring now to Figure 1, an electrode assembly constructed in accordance with this invention includes an electrode carrier 10 formed of an elongated member 12 made of a plastic material such as Silastic™ MDX 4-4210. Embedded in this member 12 is a cable 14 formed of several insulated
25 wires (not shown), each wire terminating in an electrode 16. The cable 14 is connected to a cochlear stimulation device(not shown) and is used to transmit stimulation pulses from the device to the electrodes 16. As seen in Figure 1, the electrodes 16 are all exposed. The member 12 is elastic,however, it is made from a material which has shape memory and is pre-curved so that its natural
30 configuration is in the shape of a spiral as shown. The curvature of the spiral

follows the curvature of the scala tympani of the person, and more particularly, the curvature of the modiola, as shall be described in more detail below.

After its completion, carrier 10 is distorted so that its configuration is substantially straight and is embedded into a sheath 18, as shown in Figure 2, thus forming an electrode assembly 20. Sheath 18 is made of a relatively stiff material so that it is able to retain the carrier 10 in the straight configuration shown. Importantly, sheath 18 is made of a material which dissolves, is bioresorbable or is otherwise biodegradable when immersed in cochlear fluid. For example, sheath 18 may be made of polyvinyl alcohol(PVA), polylactic acid (PLA), polyglycolic acid (PGA)and other similar compounds. Preferably the sheath 18 is made with a smooth outer surface to allow the assembly 20 to be implanted easily. A coating may be applied to this surface to reduce friction. The coating may be made of a time-released antimicrobial material to provide protection against infections during implantation. Sheath 18, while stiffer than carrier 10, must be sufficiently flexible so that it can be bent to conform to the shape of the cochlea.

A cross section for the assembly 20 is shown in Figure 3. As can be seen in this Figure, the member 18 is preferably flattened, or in the shape of a figure 8 so that it can bend more easily in a plane normal to the electrode 16. The initial position of electrode assembly 20 immediately after implantation, and the carrier 10 after the sheath 18 is dissolved can be seen in Figure 4. In this Figure, assembly 20 has been implanted into the scala tympani 22 so that it is immersed in the cochlear fluid 24. Initially, because of the stiffness of sheath 18, the assembly maintains a large radius of curvature so that it is disposed adjacent wall 25 of scala tympani 22. However in a relatively short time that can be controlled and is to be determined by the intended insertion procedures the sheath 18 dissolves in the cochlear fluid 24 releasing the carrier 10. As a result the carrier resumes its natural spiral configuration shown in Figure 1. In this configuration, the carrier 10 is disposed adjacent to the modiola 26. Importantly, in this latter configuration the electrodes 16 are facing the modiola 26 so that they are positioned as close as possible to the spiral ganglia 28 thereof. In this

manner, the electrodes 16 can generate currents and electric fields with a relatively small intensity without causing cross-channel interference.

In the embodiment of Figure 5, the carrier 10' is formed of a longitudinal support member 12' with connecting wires 14' and electrodes 16'. The carrier 5 10' is preformed into spiral shape similar to the shape of carrier 10 in Figure 1. Importantly the member 12' is formed on a side opposite electrodes 16' with a plurality of depressions or dimples 17'. The purpose of these dimples is to hold a stiffener material 19'. The stiffener 19' material is introduced into the dimples only after the carrier 10' is deformed to assume a straight or linear configuration, 10 as seen in Figure 5. The material is the same material as the material of sheath 18, that is, it is bioresorbable. In the embodiment of Figure 5, the material 19' provides rigidity to the carrier 10' to prevent the carrier 10' from taking its spiral shape. In this manner, the carrier 10' can be readily implanted into the scala tympani. After implantation, the material 19' dissolves in the cochlear fluid and 15 allows the carrier 10' to move back to its spiral shape.

Yet another embodiment of the invention is shown in Figure 6. In this embodiment, carrier 110 is provided with a plurality of longitudinally spaced fins 112 formed on generally tubular body 114. The fins 112 are relatively elastic. In the normal position as shown in Figure 6, these fins 112 extend towards the tip 20 of the carrier. Preferably the free ends 118 of the fins are curved slightly in the longitudinal direction. After the carrier 110 is formed as shown in Figure 6, the fins are forced into a position where they are disposed generally in parallel with and adjacent to the body 114 as shown somewhat diagrammatically in Figure 7. The carrier 110 thus deformed is then encased in a sheath 120 formed of a 25 biodegradable material-like sheath 18. In order to reduce the cross sectional dimensions of the carrier in this second configuration, the body 114 may be formed with a channel. Thus for example, the carrier 110 may include body 114 formed with a channel 122 for housing, in the second configuration, fin 112. As with the previous embodiment, the carrier 110 also includes connecting wires 30 124 embedded in body 114 and a plurality of electrodes 126. The advantage of this embodiment is that, after the assembly of figure 8 is implanted, and after the

sheath 120 dissolves, the fins 112 are released from channel 122 until their free ends 118 engages wall 25, thereby urging and biasing body 114 toward the modiola 26, as shown in Figures 9 and 10. This whole process is shown in more detail in Figures 11 and 12. The assembly 130 formed of the carrier 110 and sheath 120, as shown in Figure 8, is first inserted into the scala tympani 22. After the assembly 130 is fully inserted, the sheath 120 dissolves leaving the carrier 110 firmly seated with the scala tympani 22 as seen in Figure 12. If it is required to remove the carrier 110 for any reason, as indicated in Figure 13 in the direction A, the fins 112 bend back to the position 112', as shown.

10 As can be seen in Figure 12, the carrier 110 is firmly seated and positioned in the scala tympani by the interference fit and biasing provided by the fins 112 between the body 114 and the walls of the scala tympani 22. Therefore, the body 114 can, but need no be, made in the spiral shape shown in Figure 1, and need not be made of a shape-retaining material, like carrier 10.

15 Although the preferred embodiments of the invention have been described in conjunction with a cochlear electrode assembly, it should be understood that its teachings may be applicable for other implanted electrodes, such as the electrodes used in pacemakers. For this latter implementation of the invention, the tines used to secure the distal end of the electrode to an internal cardiac wall, are initially folded and maintained in a closed position by a bioabsorbable sheath or other similar means in a manner similar to the way the fins 112 are folded in Figure 7. After implantation the sheath dissolves allowing the tines to open and engage the cardiac walls, thereby securing the electrode.

25 Although the invention has been described with reference to several particular embodiments, it is to be understood that these embodiments are merely illustrative of the application of the principles of the invention. There may be multiple stiffening elements in particular implementations. Further, depending upon the resilience of the array and the mechanical structure selected, the stiffening elements may simply soften, rather than fully degrade, and yet allow the array to assume the desired operative configuration. The stiffening elements may be formed within the structure of the array, rather than

on the external surface of it. Accordingly, the embodiments described in particular should be considered exemplary, not limiting, with respect to the following claims.

Claims

1. An implantable therapeutic device comprising:
an elongated member having a first configuration selected for easy insertion of said member into a body, and a second configuration selected for applying therapy; and a stiffening member associated with said elongated member to bias said elongated member to said first configuration, said stiffening member being made of a material responsive to body fluids so that on implantation said stiffening member disassociates or softens, allowing said elongated member to assume said second configuration.
2. The device of claim 1, wherein said material responsive to bodily fluids is bioresorbable.
3. The device of claim 1 wherein said elongated member has an elastic body preformed to said second position.
4. The device of claim 1 wherein said elongated member includes a longitudinal body made of an elastic material and a plurality of positioned fins associated with said body for positioning said body in said second configuration after said stiffening member has dissolved.
5. The device of claim 4 wherein said fins are disposed adjacent to said body in said first configuration.
6. A cochlear implant electrode assembly comprising:
an elongated electrode carrier having an elastic body, said body having a first configuration selected to ease the insertion of said carrier into a patient's cochlea, and a second configuration in which said carrier is curved to match a surface of said cochlea;
a plurality of electrodes mounted on said carrier for applying stimulation pulses; and
stiffening means associated with said carrier for setting said body into said first configuration, said stiffening means being made of a material responsive to bodily fluids which disassociates on insertion into said cochlea to permit said body to take said second configuration.

7. The assembly of claim 6, wherein said material responsive to bodily fluids is bioresorbable.
8. The assembly of claim 6 wherein in said first configuration said body is substantially straight.
9. The assembly of claim 6 wherein said body is provided with a plurality of elastic fins which in said first configuration are disposed adjacent to said body, and in said second configuration extend away from said body to engage a cochlear wall.
10. The assembly of claim 9 wherein said body is formed with a channel, and in said first configuration said fins are disposed in said channel.
11. The assembly of claim 6 wherein said body is made of a plastic material with memory and is preformed to said first configuration.
12. The assembly of claim 11 wherein said stiffening means is a sheath disposed about said body.
13. The assembly of claim 11 wherein said body is made with a plurality of indentations and said stiffening means includes a stiffening material disposed in said indentations.
14. A method of making a therapeutic device, said device having a body with a first configuration selected for ease of insertion and a second configuration for application of therapy, said method comprising the steps of:
 - setting said body in said first configuration; and applying stiffening means to said body to form a therapeutic assembly, said stiffening means being made of a material responsive to bodily fluids, whereby when said assembly is inserted into a patient, said stiffening means disassociates or softens allowing said body to take said second configuration.
15. The method of claim 14 wherein said material responsive to bodily fluids is bioresorbable.
16. The method of claim 14 wherein said body is first preformed to said second configuration.

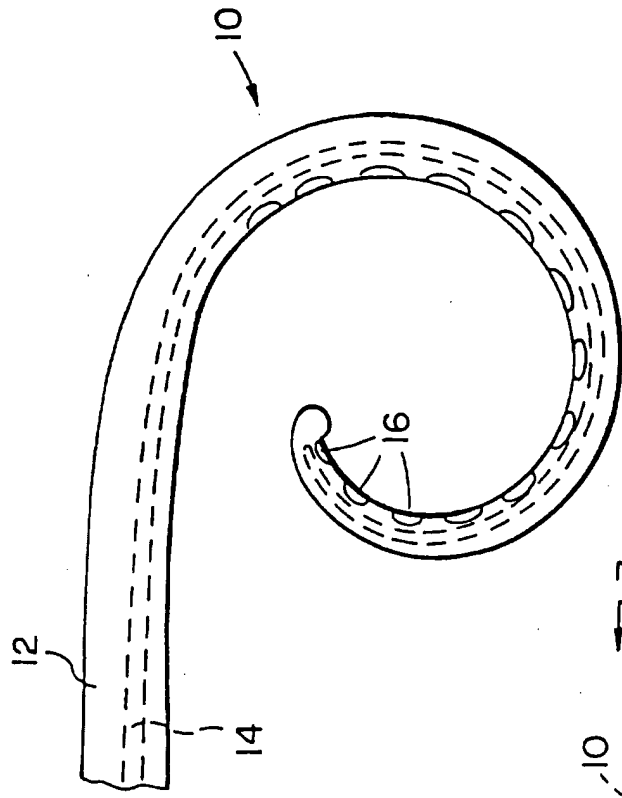

Fig 1.

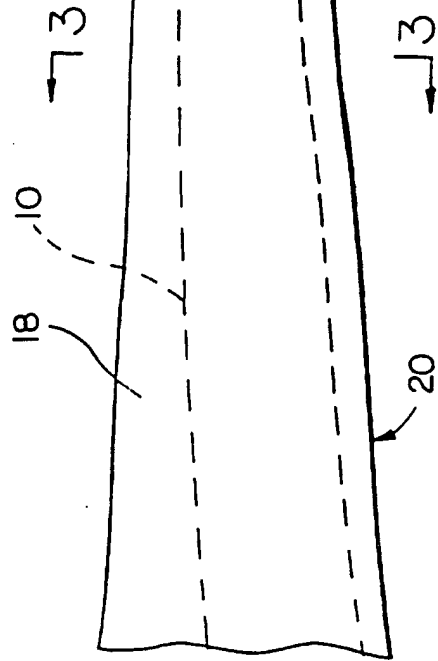

Fig 2.

Fig 3.

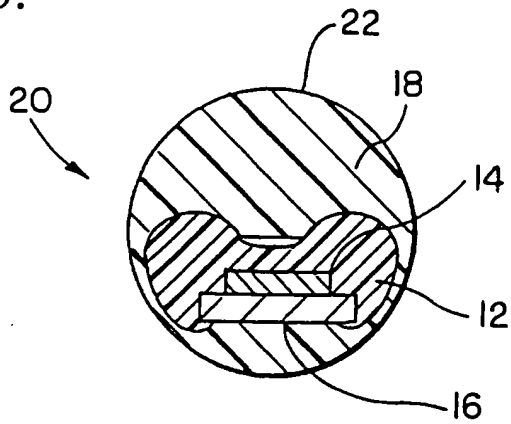

Fig 4.

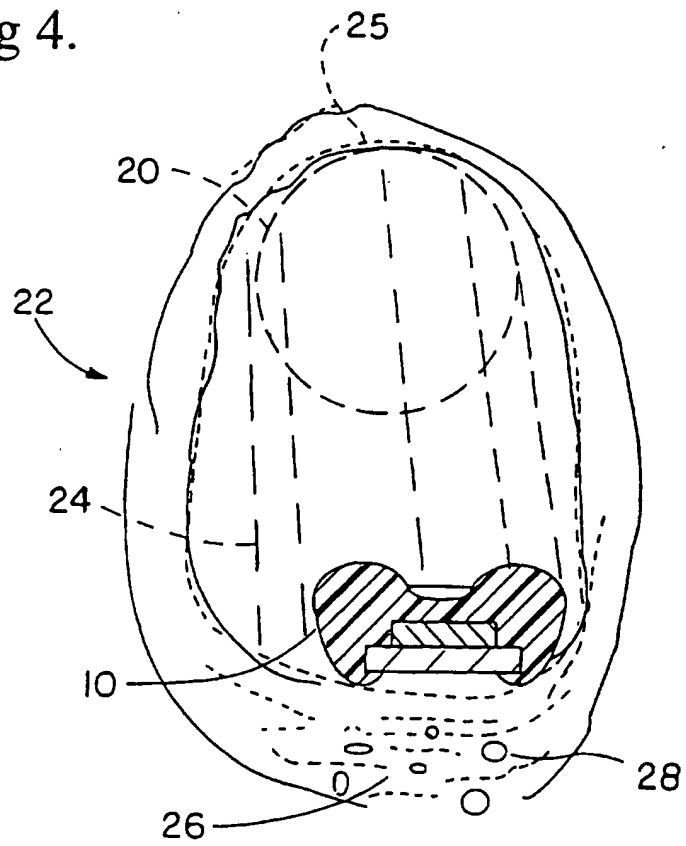

Fig 5.

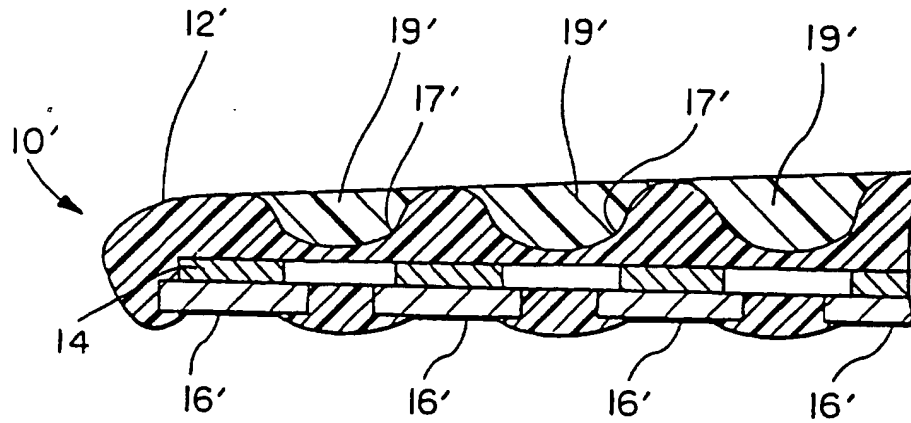

Fig 9.

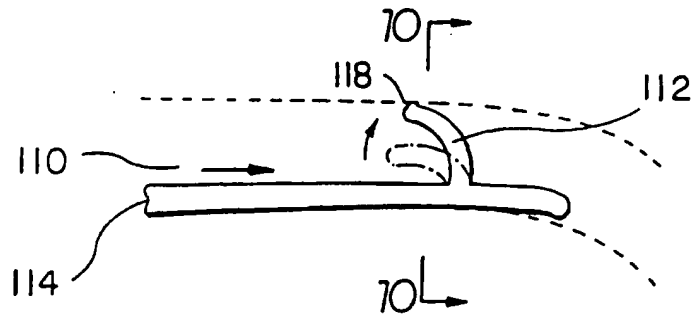

Fig 6.

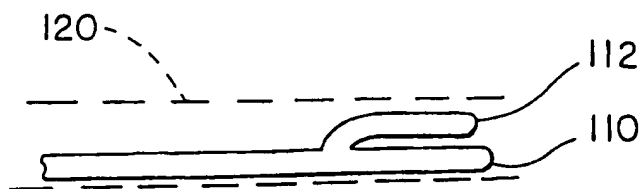

Fig 8.

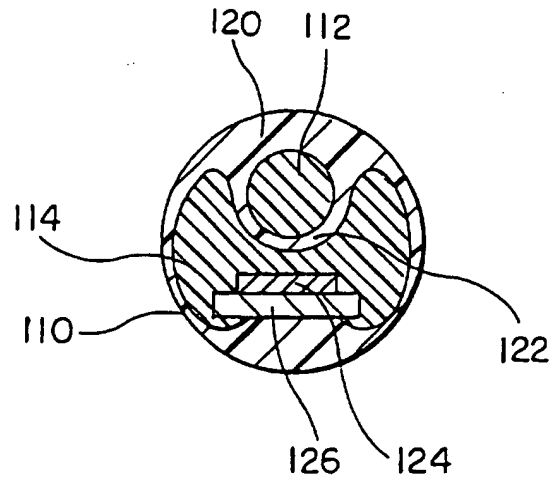

Fig 10.

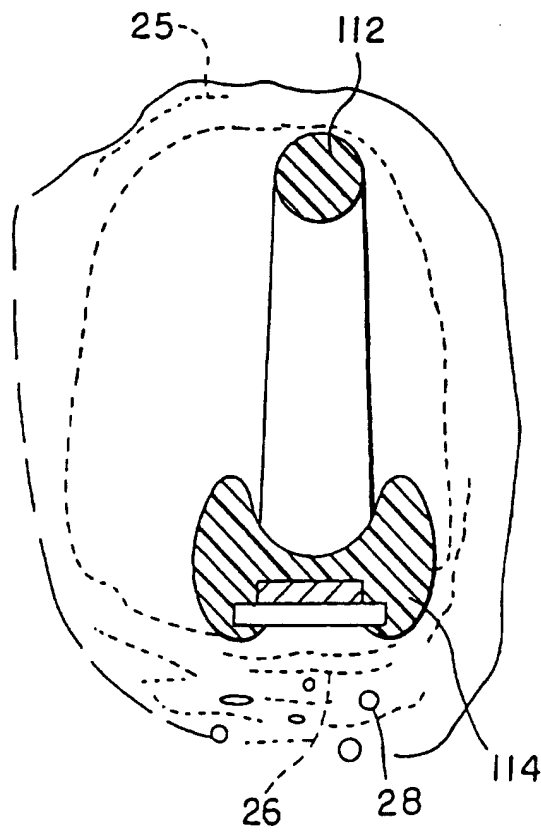

Fig 11.

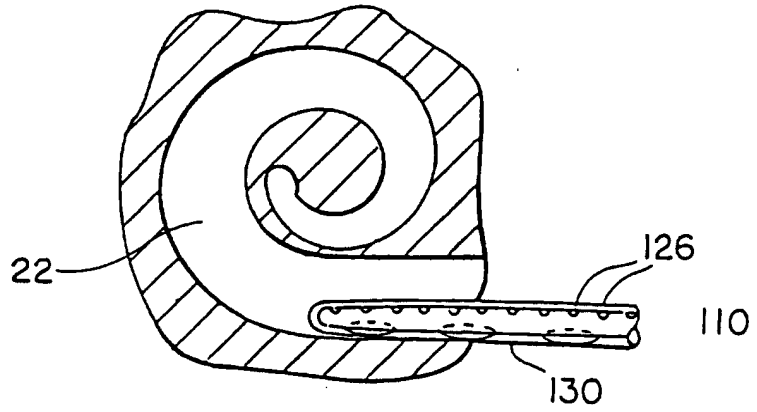

Fig 12.

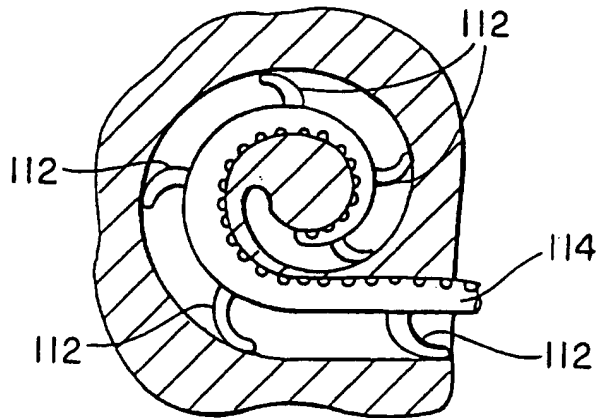

Fig 13.

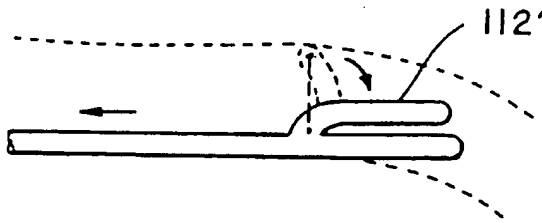
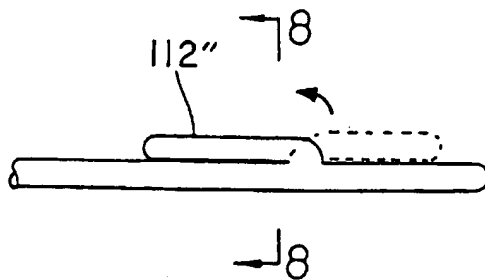

Fig 7.



INTERNATIONAL SEARCH REPORT

International Application No.
PCT/AU 95/00622

A. CLASSIFICATION OF SUBJECT MATTER		
Int Cl ⁶ : A61F 11/04 A61D 7/00 A61M 23/00 A61N 1/375		
According to International Patent Classification (IPC) or to both national classification and IPC		
B. FIELDS SEARCHED		
Minimum documentation searched (classification system followed by classification symbols) IPC A61F 11/04 A61D 7/00 A61M 23/00 A61N 1/36, 368, 372, 375		
Documentation searched other than minimum documentation to the extent that such documents are included in the fields searched AU: IPC as above		
Electronic data base consulted during the international search (name of data base and, where practicable, search terms used) DERWENT		
C. DOCUMENTS CONSIDERED TO BE RELEVANT		
Category*	Citation of document, with indication, where appropriate, of the relevant passages	Relevant to claim No.
X	AU 52510/79 A (BEECHAM GROUP LTD) 15 May 1980 Page 6, lines 25-35	1-3, 14-16
X	AU 71002/81 A (PITMAN-MOORE INC) 17 December 1981 Page 8, lines 10-25, figures 11 and 8	1-3, 14-16
X	AU 59623/80 A (BEECHAM GROUP LTD) 8 January 1981 Page 4	1-3, 14-16
<input checked="" type="checkbox"/> Further documents are listed in the continuation of Box C <input checked="" type="checkbox"/> See patent family annex		
* Special categories of cited documents: "A" document defining the general state of the art which is not considered to be of particular relevance "E" earlier document but published on or after the international filing date "L" document which may throw doubts on priority claim(s) or which is cited to establish the publication date of another citation or other special reason (as specified) "O" document referring to an oral disclosure, use, exhibition or other means "P" document published prior to the international filing date but later than the priority date claimed "T" later document published after the international filing date or priority date and not in conflict with the application but cited to understand the principle or theory underlying the invention "X" document of particular relevance; the claimed invention cannot be considered novel or cannot be considered to involve an inventive step when the document is taken alone "Y" document of particular relevance; the claimed invention cannot be considered to involve an inventive step when the document is combined with one or more other such documents, such combination being obvious to a person skilled in the art "&" document member of the same patent family		
Date of the actual completion of the international search 2 November 1995		Date of mailing of the international search report 13 NOVEMBER 1995
Name and mailing address of the ISA/AU AUSTRALIAN INDUSTRIAL PROPERTY ORGANISATION PO BOX 200 WODEN ACT 2606 AUSTRALIA Facsimile No.: (06) 285 3929		Authorized officer S. THOMAS Telephone No.: (06) 283 2454

C (Continuation) DOCUMENTS CONSIDERED TO BE RELEVANT		
Category*	Citation of document, with indication, where appropriate, of the relevant passages	Relevant to claim No.
X	EP 350188 A (PFIZER LTD) 10 January 1990 Whole document	1-3, 14-16
X	EP 2068 A (HANSEN) 30 May 1979 Pages 3 and 4	1-3, 6-7, 11-12, 14-16

INTERNATIONAL SEARCH REPORT

International Application No.

Information on patent family members**PCT/AU 95/00622**

This Annex lists the known "A" publication level patent family members relating to the patent documents cited in the above-mentioned international search report. The Australian Patent Office is in no way liable for these particulars which are merely given for the purpose of information.

Patent Document Cited in Search Report		Patent Family Member					
AU	52510/79	CA	1146821	DK	4683/79	EP	10987
		JP	55088759	NZ	192048	US	4268497
		US	4308250	ZA	7905997		
AU	71002/81	GB	2077103	US	4326522	ZA	8103828
AU	59623/80	CA	1146864	DK	2761/80	EP	21758
		JP	56008313	NZ	194120	ZA	8003681
EP	350188	AU	37839/89	CA	1330744	CN	1052785
		DK	3302/89	HU	51483	JP	2065857
		NO	892764	NZ	229808	PT	91049
		SU	1780507	US	4994275	YU	1349/89
		ZA	8905073				
EP	2068	AU	41599/78	DK	5167/77	JP	54100190
		US	4284085				
END OF ANNEX							

**This Page is Inserted by IFW Indexing and Scanning
Operations and is not part of the Official Record**

BEST AVAILABLE IMAGES

Defective images within this document are accurate representations of the original documents submitted by the applicant.

Defects in the images include but are not limited to the items checked:



BLACK BORDERS



IMAGE CUT OFF AT TOP, BOTTOM OR SIDES



FADED TEXT OR DRAWING



BLURRED OR ILLEGIBLE TEXT OR DRAWING



SKEWED/SLANTED IMAGES



COLOR OR BLACK AND WHITE PHOTOGRAPHS



GRAY SCALE DOCUMENTS



LINES OR MARKS ON ORIGINAL DOCUMENT



REFERENCE(S) OR EXHIBIT(S) SUBMITTED ARE POOR QUALITY



OTHER: _____

IMAGES ARE BEST AVAILABLE COPY.

As rescanning these documents will not correct the image problems checked, please do not report these problems to the IFW Image Problem Mailbox.